

## Taper Locking Element - N7013.0-7013.1-7030-7031-7032-7033-7134-7139-7143



N7030

### Features:

Torque transmission: High. Self centering. Low installation time. The concentricity varies from 0.02 mm to 0.04 mm (T.I.R). Interchangeable with model N7012. During installation, Model N7013.0; 7030; 7032; 7139 has light axial displacement of hub in respect of shaft, when tightening clamping screws. Model N7013.1; 7031; 7033; 7134; 7143 have No displacement of hub. Application economically advantageous.

### Installation:

Taper Locking Elements are supplied ready for installation. Unscrew all screws by 2 or 3 turns. Transfer 2 or 3 screws symmetrical opposite in the tapped holes providing in inner ring, slightly tight to separate inner & outer ring to make insertion easier. Carefully clean the hub and shaft contact surfaces and apply a light oil film. Slide the clamping unit into hub bore & onto shaft. Reposition the transferred screws in holes as was. Tighten all clamping screws gradually and regularly, using torque wrench, in crossed sequence, in several passes, until the tightening torque (as per screw size indicated) is reached. These screws close to slit, should be tightened fully last to avoid deformation in the inner/outer rings. Repeat above mentioned operation till no one screw turn more.

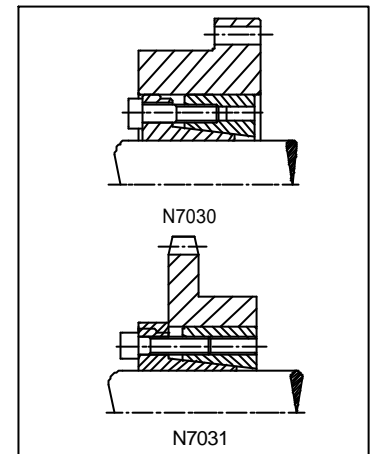

**Note:** The tightening torque values indicated is valid only in case of slight oil lubricated assembly installation. Do not use any oil with molybdenum bisulphide or high pressure additives. 2. Installations subject to corrosion, the slit should be sealed with a suitable caulking compound or rust preventives.

### Removal:

**Important:** Make sure the ends of screws used for removal are ground flat and slightly chamfered to eliminate damage to screw and removal threads.

Loosen the clamping screws. Insert (2-3) removal screws into the tapped holes provided in inner ring and tighten gradually in crossed sequence, till the assembly is released. If the assembly is to be reused, re-lubricate inner/outer ring, screws and reassemble, reuse or store.

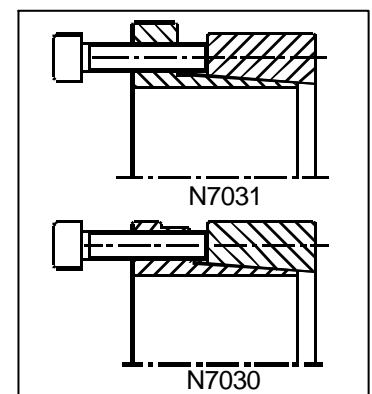

### Tolerances, surface finish:

A good surface finish by machine tool is sufficient. Maximum allowable surface finish:  $R_t \max 16 \mu m$ . Maximum permissible tolerances for hub H8 & for shaft h8.