

Locking Assembly - Model N 7012



Features:

Torque transmission : Medium / high. Not self centering. Concentricity depends on the centering guide between shaft & hub, its length & tolerance [i.e. shaft & hub bore- guiding length - it should not less than twice the width of locking assembly & its tolerance]. No displacement of hub. Low installation time. Application economically advantageous

Installation:

Carefully clean the hub and shaft contact surfaces and apply a light oil film. Slide the locking assembly into the hub bore and onto the shaft. Hand tighten all screws lightly, align hub. Use Torque wrench to tighten all screws, gradually and regularly in diametrically opposite sequence in several pass, until the tightening torque (as per screw size indicated) is reached. Check the tightening torque repeating above mentioned operation, until no one screw turn more by applied tightening torque.

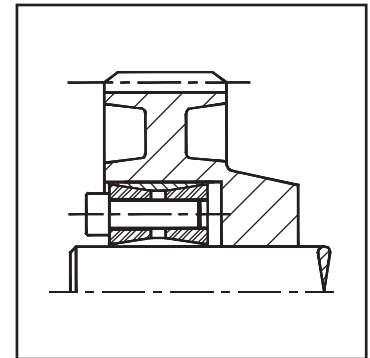

Note: The tightening torque values indicated is valid only in case of slight oil lubricated assembly installation. Do not use any oil with molybdenum bisulphide or high pressure additives and grease.

Removal:

Loosen the clamping screws. Normally, unit will be released. In case of difficulties, insert 2-3 screws, into tapped holes (provided for removal), after unscrewing plated screws and pull screws by slight hammering & push back the released screws by light hammering to push back opposite thrust nut, till the element is released. If the element is to be reused, relubricate both inner & outer rings, thrust nuts and screws & reuse / store.

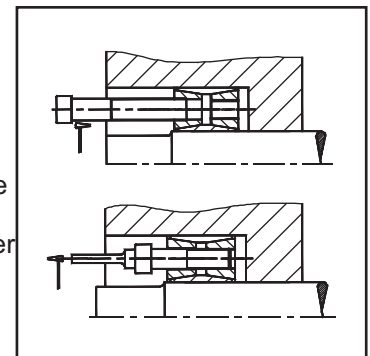

Tolerances, surface finish:

A good surface finish by machine tool is sufficient. Maximum allowable surface finish : $R_a \leq 3.2 \mu m$
Maximum permissible tolerances for hub H11 & for shaft h11.